

6 good reasons to run short bars

- ✓ Reduction of mass in movement.
- ✓ Material guiding in the Spindle enables you to utilise full lathe performances.
- ✓ Increase spindle life time.
- ✓ Easy material handling.
- ✓ No bar chamfering.
- ✓ Reduction in ambient noise.

6 good reasons to choose

MULTI-3000

- ✓ A simple, precise and proven concept.
- ✓ Unique, fast and smooth reload cycle.
- ✓ Easy handling and operating units, simple and fast on change over.
- ✓ Polyvalent, reload your round and profiled bars; swiftly change to shaft work if required.
- ✓ Maintenance free, due to its 100 % electronic control for reloading and feeding.
- ✓ Environmentally friendly.

Reliability

Produced in Germany with first class components and materials, MULTI-3000 are distinguished by exceptional strength and reliability. Simple design and handling guarantee ease of operation.

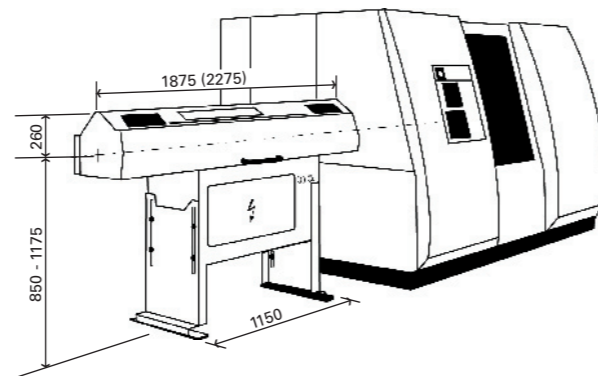
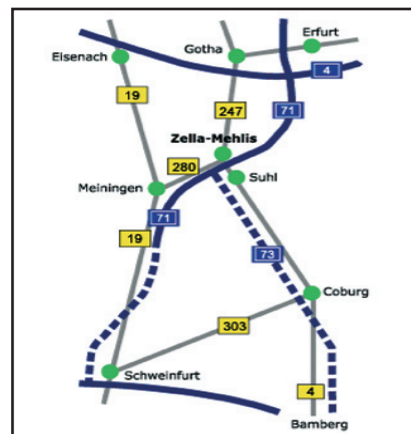

Specifications MULTI-3000

Capacity	round bars hex bars square bars bar length	5 to 55 / 65 / 80 mm 5 to 47 / 56 / 70 mm on request 150 up to 1240 / 1640 mm restricted to spindle length
Safety	electrical conformity sealing, waterproofing	EC & EMC EN 60204-1 EN 418 IP 54
Electrical Connections	supply Secondary keyboard, display	200 to 415 VAC 24/5 VDC 4 lines - 20 characters LCD backlit
Language	programming operator menu	IEC 1131-3 5 languages
Loading system	material selection material feed	reduction gear motor Servo drive
Fast speed	for pusher pusher carriage guide way	60m/min. on bearings hardened
Material positioning	at material loading at material feed	± 0.5 mm ³ ± 0.1 mm ³
Textured paint	complete unit	RAL 9018 papyrus white
Net / gross weight		390 / 560 kg
Origin	Produced in Germany	

³ Data applies to chuck / collet closing systems by traction tube withdrawal

German office

Samsys AG

Böhmstraße 1 / Industriegebiet, DE - 98544 Zella-Mehlis • Tel.: +49 3682. 452 196 • Fax: +49 3682. 452 198

Distributor

MULTI-3000

at the leading edge of technology



Efficient

Full „Servo-Driven-magazine“ permits:
- Smooth feeding cycles.
- Optimal automatic control of material feeding.
- Accurate bar positioning without a mechanical stop.

Robust, reliable

Pioneers of the „Servo“ bar feeders, MULTI-3000 are high quality units produced in Germany.

Fast

On material reload
On material feeding
On change over and set-up

Easy handling

Easy access to all elements.
Easy to understand and handle.

100% electrically operated

The MULTI-3000 units are fully electrically „Servo-Driven“ operated. No air connection / supply, and are environmentally friendly.

Proven units

In use world wide since 1998, with over 2000 full electric units running to customer satisfaction, the family of MULTI's magazine barfeeders are market leaders.

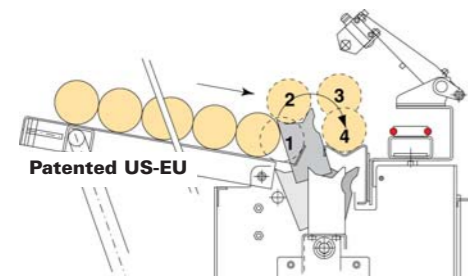

No impact on the bar feeder

- Unique loading cycle by rotary movement.
- Accurate bar selection.
- Bars stored on the table follow the movement and are retained by the selector grips.
- The selected bar is gently placed on the V loader.

No impact on the lathe

- V loader remains fixed and perfectly aligned with the lathe spindle during the barfeed cycle.
- No risk of impact by the bar on the lathe clamping cylinder.
- The "Servo" permits accurate positioning of the bar without turret stop³

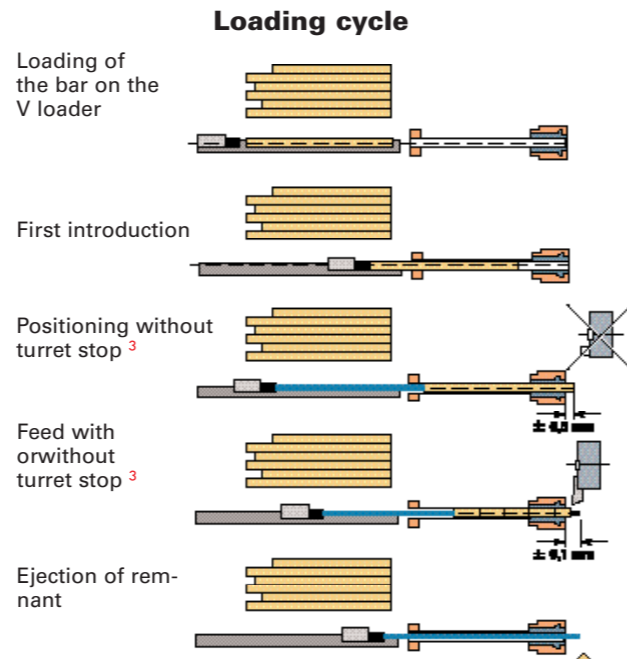

³ Data applies to chuck / collet closing systems by traction tube withdrawal

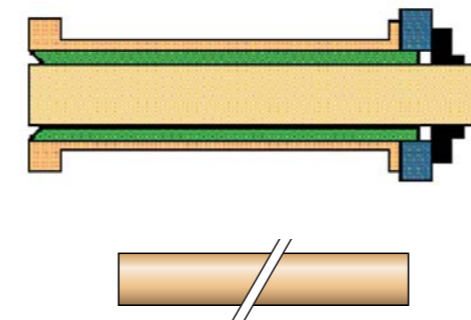
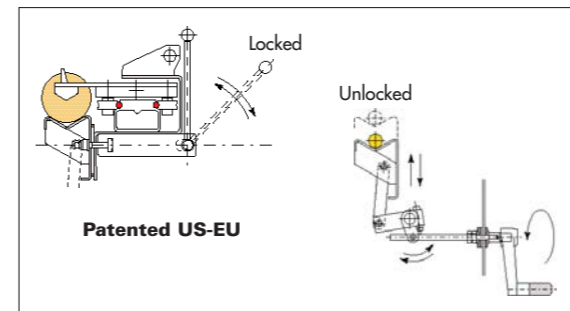

Set-up in 3 minutes

- Unlock and lower V-loader.
- Replace spindle reduction sleeve.
- Raise V loader, centre new bar, lock V loader.
- Move table or adjust loading grippers according to the new bar.
- Enter part parameters.

High speed machining

Material guiding in the spindle by reduction sleeves allows precision machining at high speed

No bar chamfering

No need to chamfer your bars, a deburring will do.

MULTI-profile V-loader

- Change from round to profiled bars without changing the channel



Polyvalent

Automatic reload of the bars and shafts, with MULTI-3000 is just a simple question of parameter alteration.

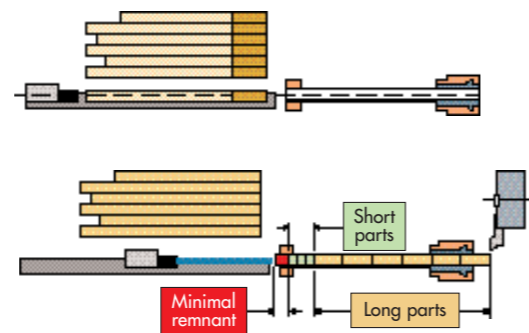

Minimize your bar remnant

In so far that lathe software allows, MULTI-3000 permits the jump from long to short components on the same bar loaded in the magazine, in order to reduce the remnant to the minimum.



User friendly key-board

Easy to handle and understand, all functions are controlled with only 12 input buttons.

High performance electronic control

The control developed by SAMSYS will simplify use. Its interactive editor permanently displays:
 - Position and status.
 - Signals received and sent.
 Its self-diagnosis system permits easy rectification of any problem.



YOUR BENEFITS

- Automated production
- Productivity increase
- Manufacturing costs reduction

Front access to all main elements and adjustments

Easy change of spindle reduction sleeve up to Ø 120 mm without retracting barfeeder!

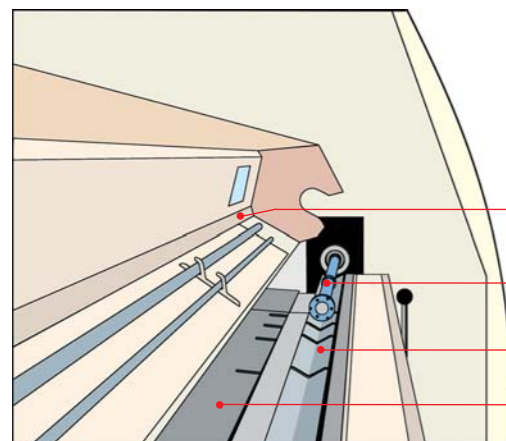

- Storage for pushers
- Spindle reduction sleeve, max. Ø 120 mm
- V loader
- Material tray

Assistance

By MODEM connection, your unit can be monitored by the SAMSYS server, to give immediate assistance and remote maintenance. A world wide distributor network also supports our products.

